

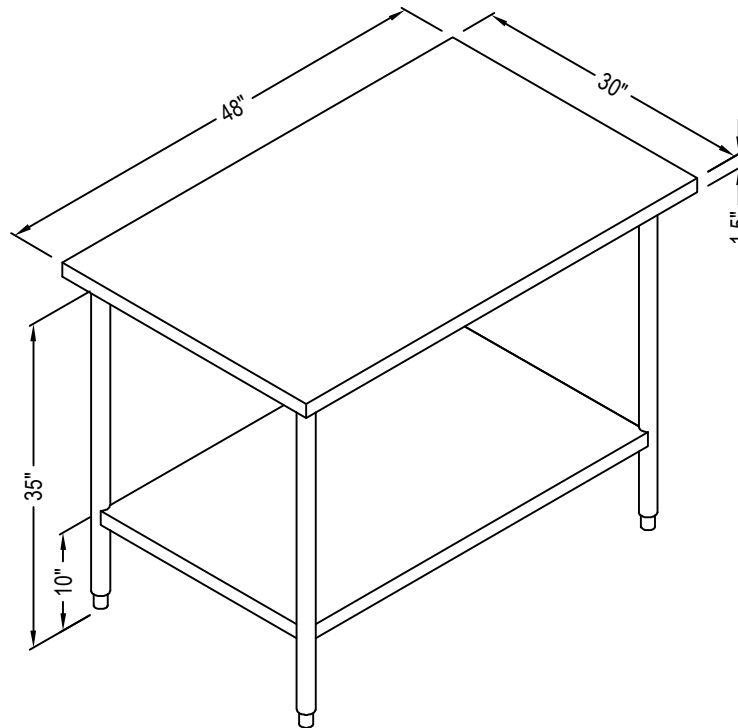

RIDALCO  
4-1084 KENASTON ST.  
OTTAWA, ON K1B 3P5  
TOLL FREE: 1-800-445-1097  
PHONE: (613) 745-9161  
FAX: (800) 268-6526  
www.ridalco.com

SELECT DESIRED MODEL:

- SWT-03630
- SWT-04830 (SHOWN)
- SWT-06030
- SWT-07230
- SWT-08430
- SWT-09630
- SWT-10830
- SWT-11630
- SWT-12030



ISOMETRIC

SPECIFICATIONS:

- WORK TABLES SHALL BE PROVIDED WITH LAMINATED HARDWOOD (WT SERIES) OR STAINLESS STEEL (SWT SERIES) WORK TOPS AS INDICATED.
- SUPPORT LEGS AND BRACING SHALL BE TUBULAR STEEL; LEGS SHALL BE EQUIPPED WITH ADJUSTABLE LEVELING FEET.
- UNDER-SHELVES SHALL BE MANUFACTURED FROM HEAVY-DUTY, REINFORCES, WELDED TO THE SUPPORT LEGS.

NOTES:

1. INSTALLATION TO BE COMPLETED IN ACCORDANCE WITH MANUFACTURER'S SPECIFICATIONS.
2. DO NOT SCALE DRAWING.
3. THIS DRAWING IS INTENDED FOR USE BY ARCHITECTS, ENGINEERS, CONTRACTORS, CONSULTANTS AND DESIGN PROFESSIONALS FOR PLANNING PURPOSES ONLY. THIS DRAWING MAY NOT BE USED FOR CONSTRUCTION.
4. ALL INFORMATION CONTAINED HEREIN WAS CURRENT AT THE TIME OF DEVELOPMENT BUT MUST BE REVIEWED AND APPROVED BY THE PRODUCT MANUFACTURER TO BE CONSIDERED ACCURATE.
5. CONTRACTOR'S NOTE: FOR PRODUCT AND COMPANY INFORMATION VISIT [www.CADdetails.com/info](http://www.CADdetails.com/info) AND ENTER REFERENCE NUMBER 4396-014.

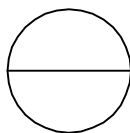

**WORK TABLES**

WORK TABLE